

APR 22/40

REVERSIBLE VIBRATORY PLATE



FAST WORKER AND A GOOD CLIMBER

The light weight and narrow width of the APR 22/40 make this reversible plate compactor a great fit especially on small or confined worksites. With a working width of 40 cm and a weight of about 100 kg (220 lb) with the petrol engine and 118 kg (260 lb) with the diesel engine, this vibratory plate squeezes into tight locations. It's ability to overcome steep grades and move quickly on even and uneven surfaces allow a wide range of applications that the APR 22/40 you can use this machine for.

PRODUCTIVITY

Superior compaction performance

Powerful vibratory system generates high compaction forces for fast, comprehensive compaction.

Unmatched speed

Balanced base plate enables superior mobility and high working speed.

Hydrostatic steering control

Provides simple control and high accuracy even in confined areas.

ERGONOMICS

Low-vibration guide handle

Industry-leading HAV values below 2.5 m/sec² protect operator and eliminate need for time-consuming record keeping.

Convenient guide handle

Ergonomically optimised for ideal machine control during the working shift.

Secure transport

Machine is easily secured during transport for convenience and safety.

SERVICEABILITY

Toolless daily inspection

Quick and easy daily inspection.

Simplified maintenance work

Service and regular maintenance points are quick and easily accessible.

Protective frame and covers

Protects all key components against damage on the jobsite or during transport.

APPLICATIONS

- Earthwork and paving applications
- Road and rail track construction
- Compaction work in narrow trenches, confined areas
- Landscape and gardening
- Foundation work
- Sensitive surfaces (with optional rubber mats for stone protection)

AMMANN

TECHNICAL SPECIFICATIONS
APR 22/40 REVERSIBLE VIBRATORY PLATE

WEIGHT & DIMENSIONS

	PETROL	DIESEL
MACHINE WEIGHT	100 kg (220 lb)	118 kg (260 lb)
MACHINE WEIGHT (WITH OPTIONS)	108 kg (238 lb)	130 kg (287 lb)
A BASE PLATE LENGTH	254 mm (10.0 in)	254 mm (10 in)
B MACHINE LENGTH	600 mm (23.6 in)	600 mm (23.6 in)
C WITH HANDLE	1140 mm (44.9 in)	1140 mm (44.9 in)
D MACHINE HEIGHT	625 mm (24.6 in)	725 mm (28.5 in)
E HANDLE HEIGHT (WORK)	1000 mm (39.4 in)	1000 mm (39.4 in)
F HANDLE HEIGHT (TRANSPORT)	1180 mm (46.5 in)	1180 mm (46.5 in)
G MACHINE WIDTH	400 mm (15.7 in)	400 mm (15.7 in)

ENGINE

ENGINE	Honda GX 160	Hatz 1B20
FUEL	Petrol	Diesel
ENGINE OUTPUT AT RPM	5 HP / 3.7 kW 3600	4.2 HP / 3.1 kW 3000
FUEL CONSUMPTION	0.9 l/h (0.2 gal/h)	0.9 l/h (0.2 gal/h)

COMPACTION FORCES

MAX. VIBRATION FREQUENCY	98 Hz (5800 vpm)	98 Hz (5800 vpm)
MAX. CENTRIFUGAL FORCE	23 kN (4.9 lbf)	23 kN (4.9 lbf)
WORKING SURFACE	504 m ² /h (5425 ft ² /h)	528 m ² /min (6777 ft ² /h)
SPEC. SURFACE PRESSURE	23.62 N/cm ²	23.62 N/cm ²

MISCELLANEOUS

HAND-ARM VIBRATIONS	< 2.5m/sec ²	< 2.5m/sec ²
SPEED	22 m/min (0.8 mph)	21 m/min (0.8 mph)
FUEL TANK	2.5 l (0.7 gal)	3.0 l (0.8 gal)
GRADEABILITY	35%	35%
MAX. INCLINE TO ALL SIDES	20°	30°
WATER TANK	-	7.6 l (2 gal)

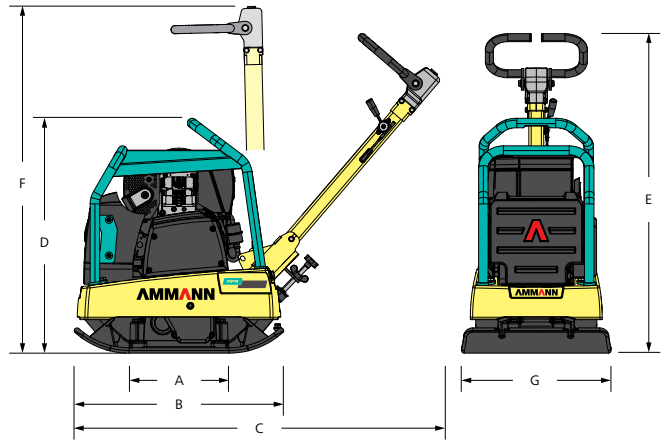

STANDARD EQUIPMENT

- Sturdy protection frame with central lifting point
- Vibration isolated handle bar
- Powerful and reliable petrol or diesel engine
- 2-shaft exciter with long service intervals
- Well protected, sturdy centrifugal clutch with wear resistant V-Belt
- 3 year extended warranty program

OPTIONAL EQUIPMENT

- Toolless mountable rubber mat for applications on paving stones
- Transport wheels
- Water tank & sprinkler system (only on Diesel Version)
- Hour meter